



BEST OF CLASS

The JEWELL LSO Series is our most rugged general-purpose inclinometer. Our Jewell LSO inertial sensors meet the needs of a variety of commercial and industrial applications. They offer precise readings with high outputs at lower range frequencies. We machine each housing from solid aluminum making the LSO ideal for "all weather" applications.

LSO Inclinometer Specifications

Performance

Input Range, °:	±1	±3	±14.5	±30	±90
Full Range Output (FRO), VDC ±1% ¹ :	±5.0	±5.0	±5.0	±5.0	±5.0
Nonlinearity, % FRO ² , maximum:	0.05	0.05	0.02	0.02	0.05
Scale Factor, volts/g nominal:	286.5	95.5	20.0	10.0	5.0
Scale Factor Temp Sensitivity, PPM/°C, maximum:	400	300	100	60	60
Natural Frequency, Hz, nominal ³ :	0.5	2.0	15.0	20.0	40.0
Bandwidth (-3db), Hz, nominal:	0.5	2.0	15.0	20.0	40.0
Input-Axis Misalignment, °, maximum:	0.1	0.15	0.25	0.5	1.0
Output at 0° Tilt, volts, maximum:	0.1	0.04	0.02	0.02	0.02
0° Output Temp Sensitivity, volts/°C, maximum:	0.005	0.003	0.001	0.0005	0.0003
Resolution and Threshold:	1µradian				

Electrical

Input Voltage, VDC ⁴ :	±12 to ±18
Input Current, mA, nominal:	±15
Output Impedance, ohms, nominal:	100
Noise, Vrms, maximum:	0.002

Environmental

Operating Temp Range:	-18° C to +71° C
Survival Temp Range:	-40° C to +71° C
Vibration:	20 grms
Shock:	1500g, 0.5 msec, 1/2 sine
Seal:	MIL-STD 202, Method 112
Weight:	13.0 oz.

¹ Full Range is defined "from negative full input angle to positive full input angle."

² Nonlinearity is specified as deviation of output referenced to theoretical sine function value, independent of misalignment.

³ Output Phase angle = -90°.

⁴ Unit Power connections can be easily adapted for operations from single-ended, floating power supplies of 24 to 36 Volts DC.

Applications

- ▶ Heavy Construction, Grading
- ▶ Ship & Barge Leveling
- ▶ Deviation Surveys
- ▶ Continuous Casting
- ▶ Weapons Platform Leveling

Supplied in partnership with Jewell Instruments



Polaron Components Limited

26 Greenhill Crescent, Watford Business Park, Watford, Herts, WD18 8XG. UK

Tel: +44 (0)1923 495401. Fax: +44 (0)1923 495416. E-mail: components@polaron.co.uk Web: www.polaron.co.uk

BS EN ISO 9001 : 2000 - ISO Number FM 70209

Dimensional Drawing for the LSO Inclinometer (inch/mm)

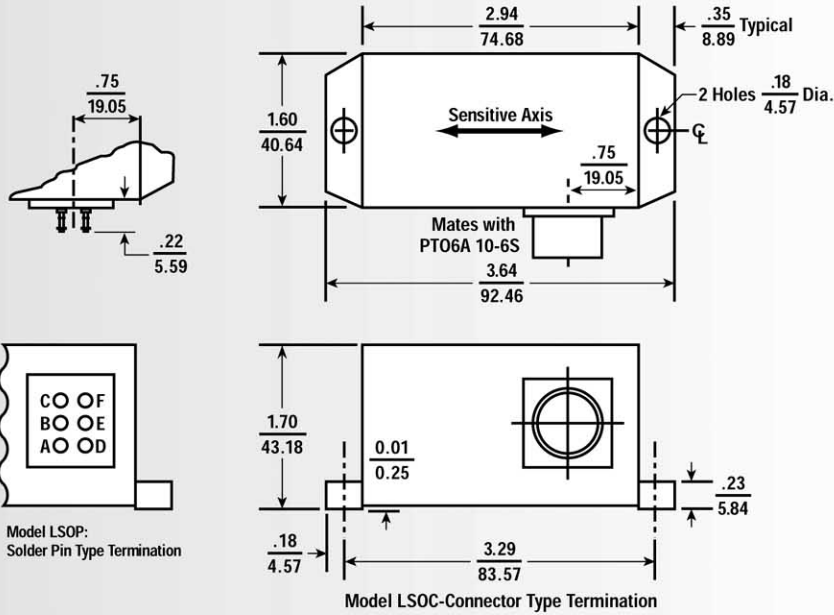

Block Diagram for the LSO Inclinometer

